

Detail Z

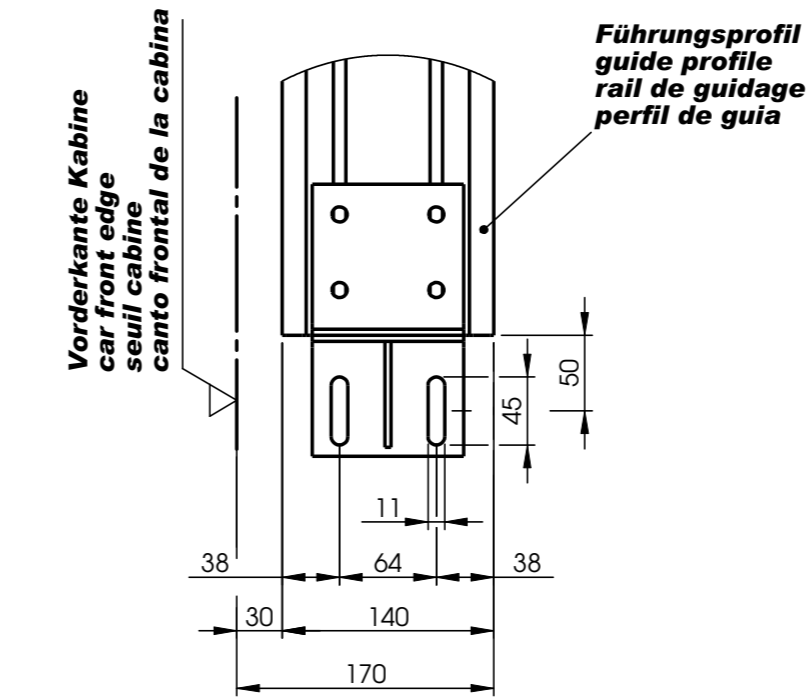

Detail Y

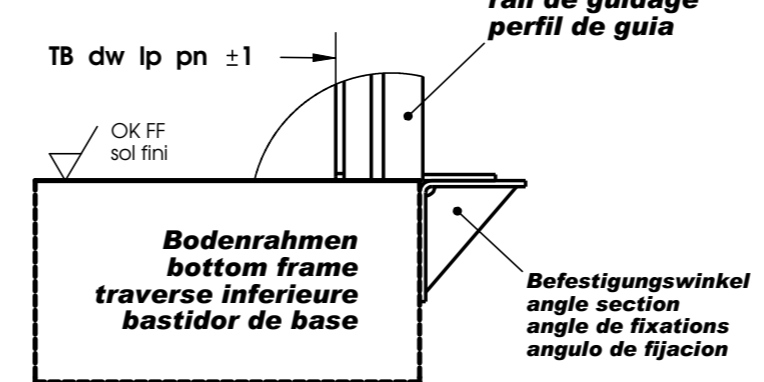

Option
Opcion

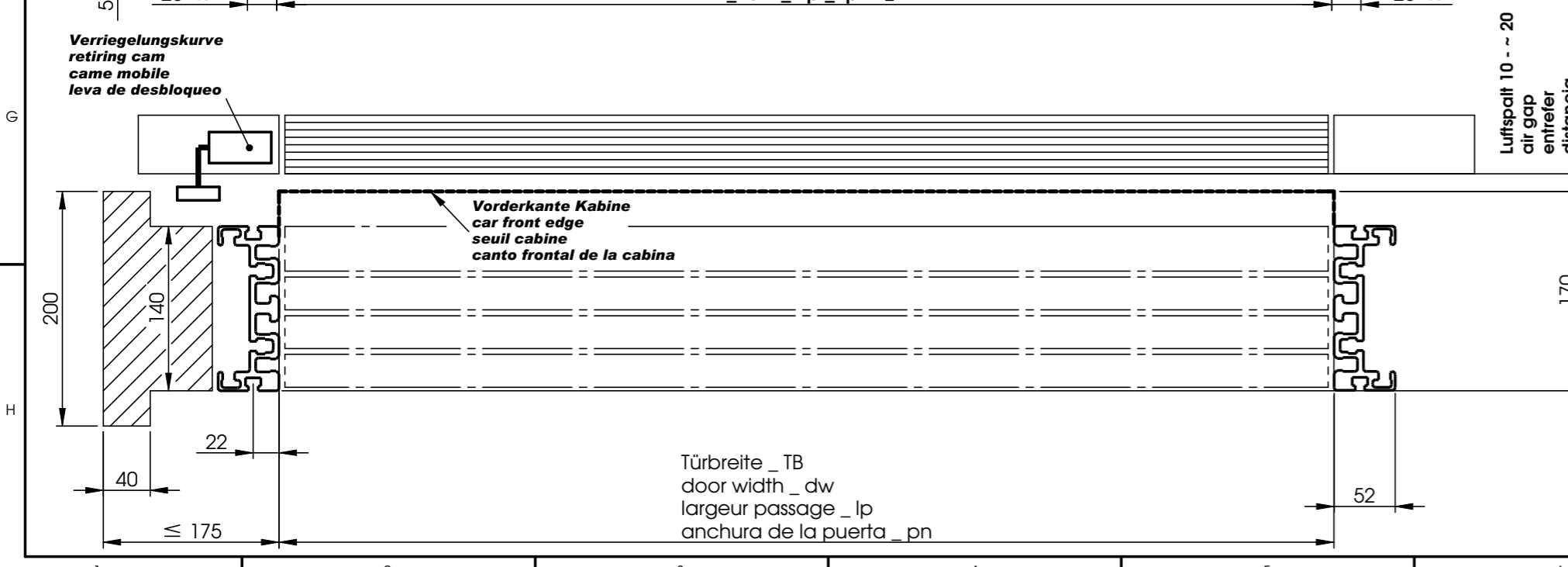
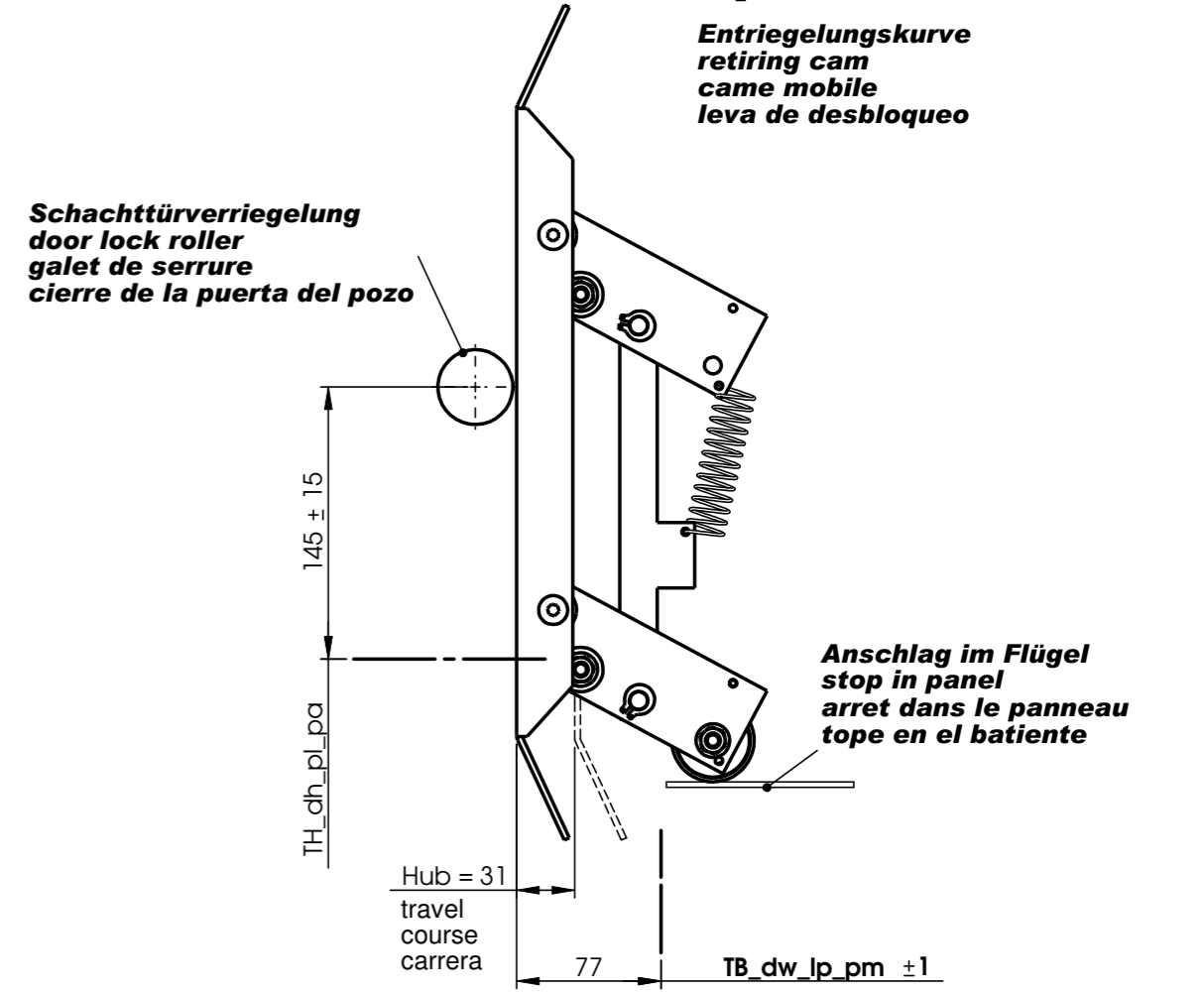

Gegengewicht rechts wie gezeichnet, links spiegelbildlich
counterweight right as drawn, left mirror-image
contrepoids droit de tirage, laissé image miroir

Türbreite TB_ door width dw_ largeur passage lp_ anchura de la puerta pn
Türhöhe TH_ door height dh_ hauteur passage hp_ altura de la puerta pa

		HÜTTER GmbH Siemensstr.11, 21509 Glinde Tel. 040/727766 - 0, Fax -55	Maßstab 1:5	Gewicht
Datum 11.08.2009		Gezeichnet Jakob	Vertikale Kabinentür - VKT m. eins. Gegengewicht vertical car door - VKT with one side counterweight porte coulissante verticalement - VKT puerta verticala - VKT	
Geprüft		Norm DIN 7168 - m	Zeichnung Nr.	
Auftrag Nr.		Bl. 1 von 1		ÄZ
23.08.2011		21617 - 2		02
06.12.2010		T:\SolidWorks\HutTurVKT 2011\Version 2011 eins.GG\VKT eins.GG\		
Bemerkung		Datum		Bearb.